

Catalog

IC310-4E.pdf	1
IC355-4-6D.pdf	2
IC355-4E.pdf	3
IC400-4E.pdf	4
IC450-4-6D.pdf	5
IC450-4E.pdf	6
IC500-4-6D.pdf	7
IC500-4E.pdf	8
IC560-4-6D.pdf	9
IC630-4-6D.pdf	10
IC630-6-8D.pdf	11
IC710-6-8D.pdf	12



IC310-4E

INLINE CENTRIFUGAL FAN



FAN FEATURES

- INLINE CENTRIFUGAL BOX FAN.
- CAPABLE OF HANDLING UP TO 500 L/s.
- USED FOR GENERAL VENTILATION.
- ALL METAL CONSTRUCTION.
- WEATHER PROOF DESIGN.
- SPEED CONTROLLABLE.
- EASY TO MAINTAIN
- SQUARE FLANGE CONNECTION
- FULL COMPLIANCE WITH AUSTRALIAN STANDARDS AIRFLOW TEST TO BS848 PART 1 & NOISE TEST TO BS848 PART 2

DIMENSIONS

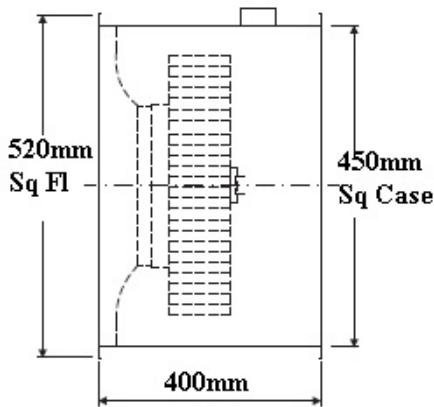

PERFORMANCE

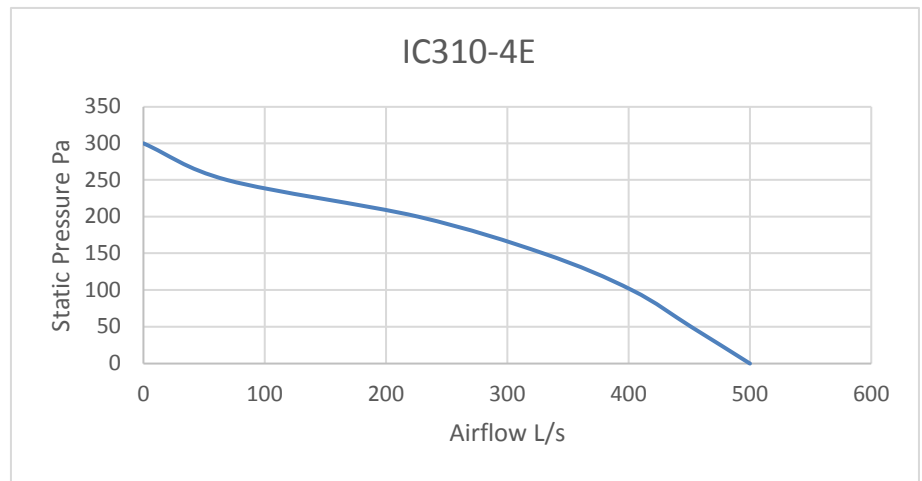

SOUND DATA

Model	Octave Band Frequency Lw db (A)								Lw dB (A)	SPL dB (A) @3m
	63	125	250	500	1K	2K	4K	8K		
IC310-4E	27	51	55	65	67	54	58	51	69	48

TECHNICAL DATA

Fan Model	RPM	1 Phase KW	240V Amps	3 Phase KW	415V Amps	dba @3M
IC310-4E	1390	0.12	0.55			48



**ECO DYNAMIC
FANS PTY LTD**

296 South Gippsland Hwy,
Dandenong South VIC 3175
P: 03 8578 5911

E: sales@ecodynamicfans.com.au
F: 03 8768 8529

www.ecodynamicfans.com.au



IC355-4/6D

INLINE CENTRIFUGAL FAN



FAN FEATURES

- INLINE CENTRIFUGAL FAN. CAPABLE OF HANDLING UP TO 900 L/s.
- USED FOR COMMERCIAL KITCHEN APPLICATIONS AND GENERAL VENTILATION.
- WEATHER PROOF HOUSING.
- GALVANIZED STEEL CONSTRUCTION.
- SPEED CONTROLLABLE.
- SQUARE FLANGE CONNECTION
- FULL COMPLIANCE WITH AUSTRALIAN STANDARDS AIRFLOW TEST TO BS848 PART 1 & NOISE TEST TO BS848 PART 2

DIMENSIONS

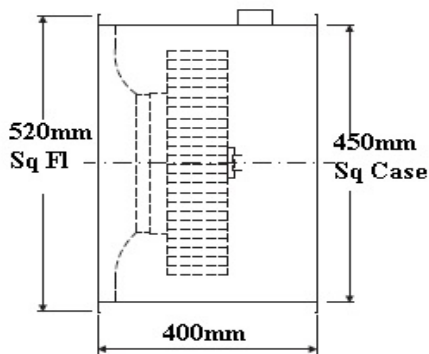

PERFORMANCE

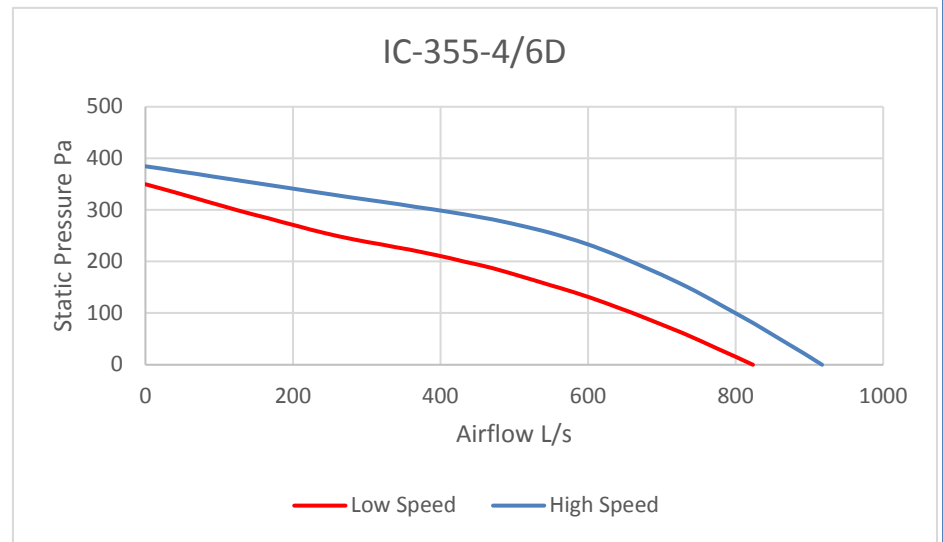

SOUND DATA

Model	Octave Band Frequency Lw db (A)								Lw dB (A)	SPL dB (A) @3m
	63	125	250	500	1K	2K	4K	8K		
IC355-4D	79	77	73	71	62	64	64	63	73	52
IC355-6D	75	67	64	61	57	51	46	43	64	43

TECHNICAL DATA

Fan Model	RPM	1 Phase KW	240V Amps	3 Phase KW	415V Amps	dba @3M
IC355-4D	1320			0.25	0.49	52
IC355-6D	1020			0.18	0.93	43



**ECO DYNAMIC
FANS PTY LTD**

296 South Gippsland Hwy,
Dandenong South VIC 3175

P: 03 8578 5911

E: sales@ecodynamicfans.com.au

F: 03 8768 8529

www.ecodynamicfans.com.au



IC355-4E

INLINE CENTRIFUGAL FAN



FAN FEATURES

- INLINE CENTRIFUGAL FAN. CAPABLE OF HANDLING UP TO 700 L/s.
- USED FOR COMMERCIAL KITCHEN APPLICATIONS AND GENERAL VENTILATION.
- WEATHER PROOF HOUSING.
- GALVANIZED STEEL CONSTRUCTION.
- SPEED CONTROLLABLE.
- SQUARE FLANGE CONNECTION
- FULL COMPLIANCE WITH AUSTRALIAN STANDARDS AIRFLOW TEST TO BS848 PART 1 & NOISE TEST TO BS848 PART 2

DIMENSIONS

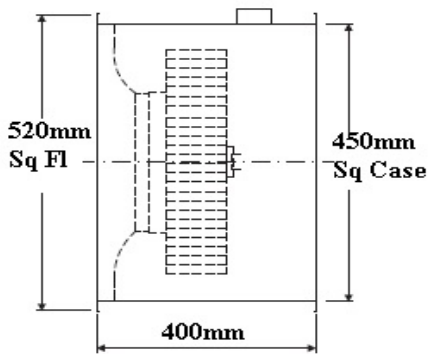

PERFORMANCE

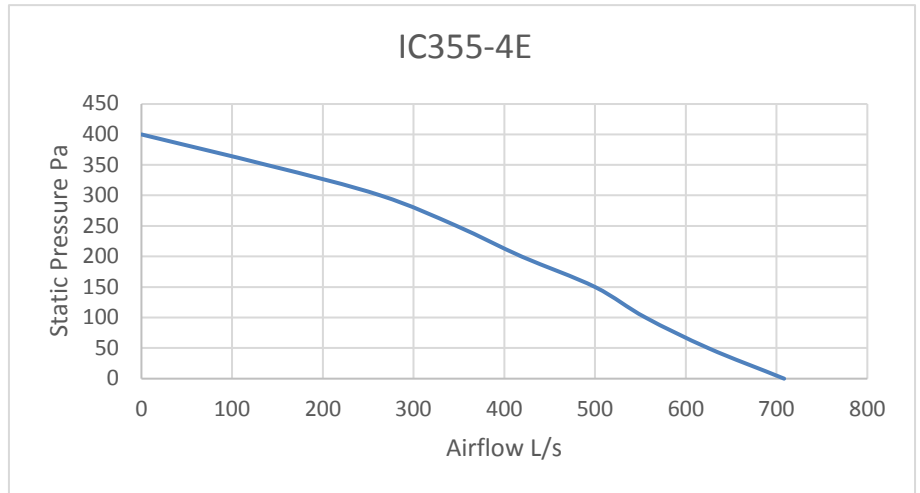

SOUND DATA

Model	Octave Band Frequency Lw db (A)								Lw dB (A)	SPL dB (A) @3m
	63	125	250	500	1K	2K	4K	8K		
IC355-4E	24	48	53	67	69	67	63	49	73	52

TECHNICAL DATA

Fan Model	RPM	1 Phase KW	240V Amps	3 Phase KW	415V Amps	dba @3M
IC355-4E	1400	0.2	1.0			52



**ECO DYNAMIC
FANS PTY LTD**

www.ecodynamicfans.com.au

296 South Gippsland Hwy,
Dandenong South VIC 3175

P: 03 8578 5911

E: sales@ecodynamicfans.com.au

F: 03 8768 8529



IC400-4E

INLINE CENTRIFUGAL FAN



FAN FEATURES

- INLINE CENTRIFUGAL FAN. CAPABLE OF HANDLING UP TO 1300 L/s.
- USED FOR COMMERCIAL KITCHEN APPLICATIONS AND GENERAL VENTILATION.
- WEATHER PROOF HOUSING.
- GALVANIZED STEEL CONSTRUCTION.
- SPEED CONTROLLABLE.
- SQUARE FLANGE CONNECTION
- FULL COMPLIANCE WITH AUSTRALIAN STANDARDS AIRFLOW TEST TO BS848 PART 1 & NOISE TEST TO BS848 PART 2

DIMENSIONS

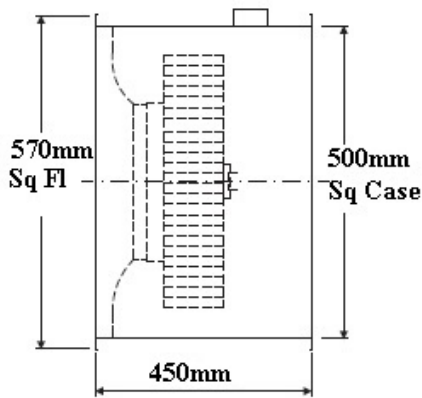

PERFORMANCE

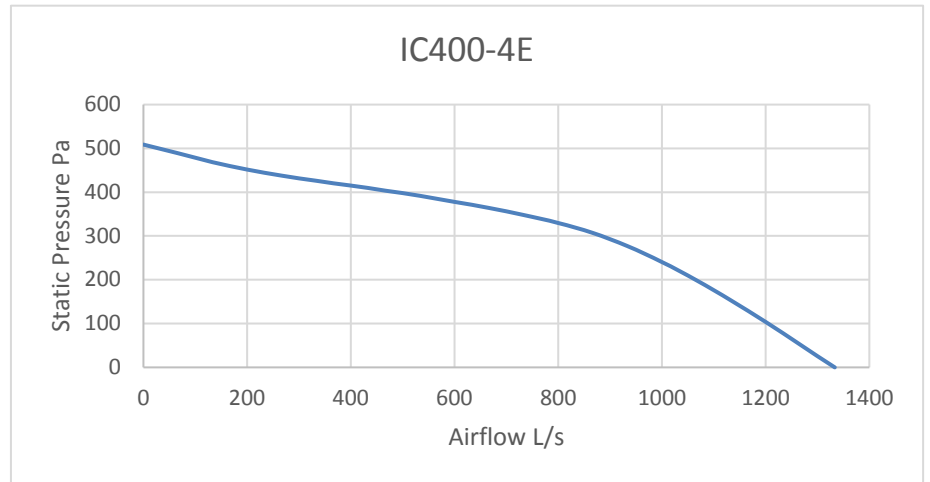

SOUND DATA

Model	Octave Band Frequency Lw db (A)								Lw dB (A)	SPL dB (A) @3m
	63	125	250	500	1K	2K	4K	8K		
IC400-4E	44	57	60	66	60	59	58	64	70	49

TECHNICAL DATA

Fan Model	RPM	1 Phase KW	240V Amps	3 Phase KW	415V Amps	dba @3M
IC400-4E	1390	0.55	2.6			49



**ECO DYNAMIC
FANS PTY LTD**

296 South Gippsland Hwy,
Dandenong South VIC 3175

P: 03 8578 5911

E: sales@ecodynamicfans.com.au

F: 03 8768 8529

www.ecodynamicfans.com.au



IC450-4/6D

INLINE CENTRIFUGAL FAN



FAN FEATURES

- INLINE CENTRIFUGAL FAN. CAPABLE OF HANDLING UP TO 1700 L/s.
- USED FOR COMMERCIAL KITCHEN APPLICATIONS AND GENERAL VENTILATION.
- WEATHER PROOF HOUSING.
- GALVANIZED STEEL CONSTRUCTION.
- SPEED CONTROLLABLE.
- SQUARE FLANGE CONNECTION
- FULL COMPLIANCE WITH AUSTRALIAN STANDARDS AIRFLOW TEST TO BS848 PART 1 & NOISE TEST TO BS848 PART 2

DIMENSIONS

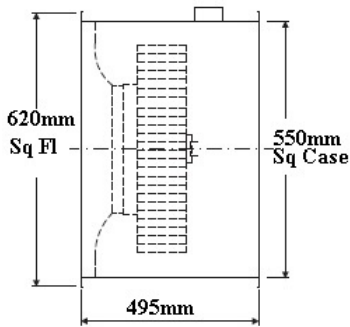

PERFORMANCE

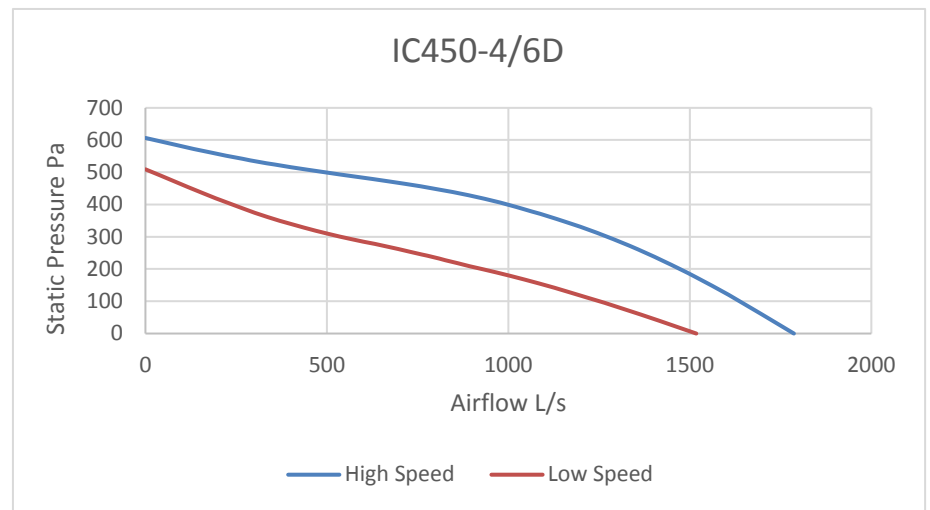

SOUND DATA

Model	Octave Band Frequency Lw db (A)								Lw dB (A)	SPL dB (A) @3m
	63	125	250	500	1K	2K	4K	8K		
IC450-4D	46	64	68	71	66	65	62	67	75	54
IC450-6D	49	55	59	61	58	57	61	54	67	46

TECHNICAL DATA

Fan Model	RPM	1 Phase KW	240V Amps	3 Phase KW	415V Amps	dba @3M
IC450-4D	1330			0.8	1.58	54
IC450-6D	1040			0.54	0.94	46



**ECO DYNAMIC
FANS PTY LTD**

296 South Gippsland Hwy,
Dandenong South VIC 3175

P: 03 8578 5911

E: sales@ecodynamicfans.com.au

F: 03 8768 8529

www.ecodynamicfans.com.au



IC450-4E

INLINE CENTRIFUGAL FAN



FAN FEATURES

- INLINE CENTRIFUGAL FAN, CAPABLE OF HANDLING UP TO 1600 L/s.
- USED FOR COMMERCIAL KITCHEN APPLICATIONS AND GENERAL VENTILATION.
- WEATHER PROOF HOUSING.
- GALVANIZED STEEL CONSTRUCTION.
- SPEED CONTROLLABLE.
- SQUARE FLANGE CONNECTION
- FULL COMPLIANCE WITH AUSTRALIAN STANDARDS AIRFLOW TEST TO BS848 PART 1 & NOISE TEST TO BS848 PART 2

DIMENSIONS

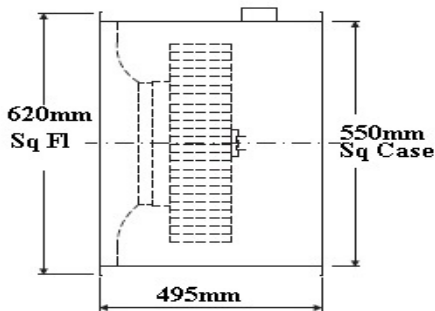

PERFORMANCE

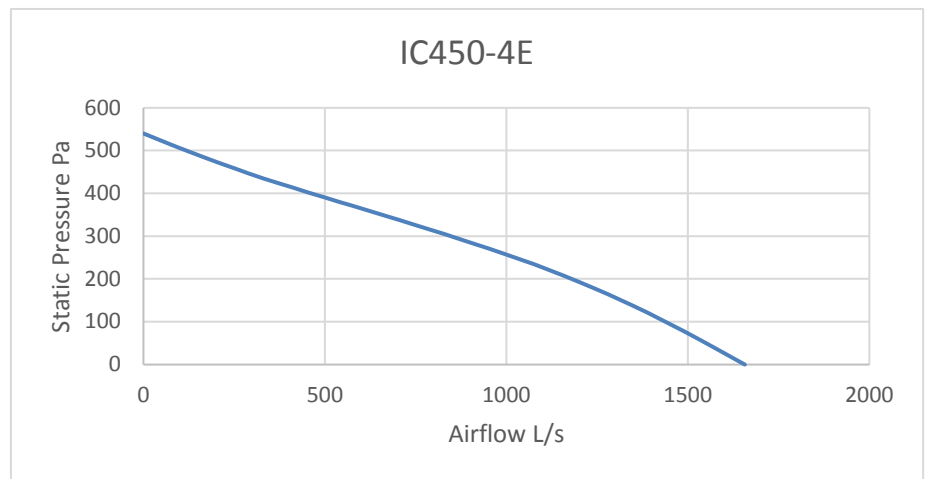

SOUND DATA

Model	Octave Band Frequency Lw db (A)								Lw dB (A)	SPL dB (A) @3m
	63	125	250	500	1K	2K	4K	8K		
IC450-4E	48	61	67	67	62	61	58	63	72	51

TECHNICAL DATA

Fan Model	RPM	1 Phase KW	240V Amps	3 Phase KW	415V Amps	dba @3M
IC450-4E	1160	0.66	3			51



**ECO DYNAMIC
FANS PTY LTD**

296 South Gippsland Hwy,
Dandenong South VIC 3175

P: 03 8578 5911

E: sales@ecodynamicfans.com.au

F: 03 8768 8529

www.ecodynamicfans.com.au



IC500-4/6D

INLINE CENTRIFUGAL FAN



FAN FEATURES

- INLINE CENTRIFUGAL FAN. CAPABLE OF HANDLING UP TO 2400 L/s.
- USED FOR COMMERCIAL KITCHEN APPLICATIONS AND GENERAL VENTILATION.
- WEATHER PROOF HOUSING.
- GALVANIZED STEEL CONSTRUCTION.
- SPEED CONTROLLABLE.
- SQUARE FLANGE CONNECTION
- FULL COMPLIANCE WITH AUSTRALIAN STANDARDS AIRFLOW TEST TO BS848 PART 1 & NOISE TEST TO BS848 PART 2

DIMENSIONS

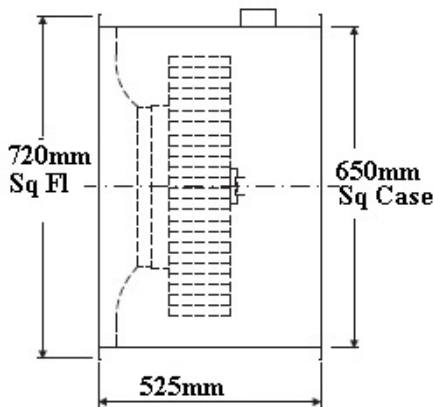

PERFORMANCE

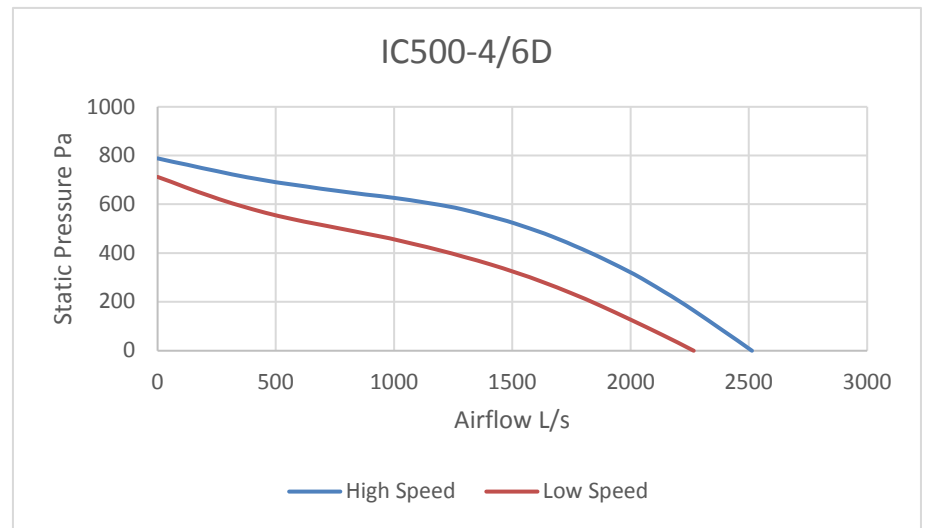

SOUND DATA

Model	Octave Band Frequency Lw db (A)								Lw dB (A)	SPL dB (A) @3m
	63	125	250	500	1K	2K	4K	8K		
IC500-4D	51	68	72	76	71	71	59	68	79	58
IC500-6D	56	58	61	63	61	57	66	59	70	49

TECHNICAL DATA

Fan Model	RPM	1 Phase KW	240V Amps	3 Phase KW	415V Amps	dba @3M
IC500-4D	1395			1.4	2.9	58
IC500-6D	1200			1.08	1.81	49



**ECO DYNAMIC
FANS PTY LTD**

www.ecodynamicfans.com.au

296 South Gippsland Hwy,
Dandenong South VIC 3175

P: 03 8578 5911

E: sales@ecodynamicfans.com.au

F: 03 8768 8529



IC500-4E

INLINE CENTRIFUGAL FAN



FAN FEATURES

- INLINE CENTRIFUGAL FAN. CAPABLE OF HANDLING UP TO 2500 L/s.
- USED FOR COMMERCIAL KITCHEN APPLICATIONS AND GENERAL VENTILATION.
- WEATHER PROOF HOUSING.
- GALVANIZED STEEL CONSTRUCTION.
- SPEED CONTROLLABLE.
- SQUARE FLANGE CONNECTION
- FULL COMPLIANCE WITH AUSTRALIAN STANDARDS AIRFLOW TEST TO BS848 PART 1 & NOISE TEST TO BS848 PART 2

DIMENSIONS

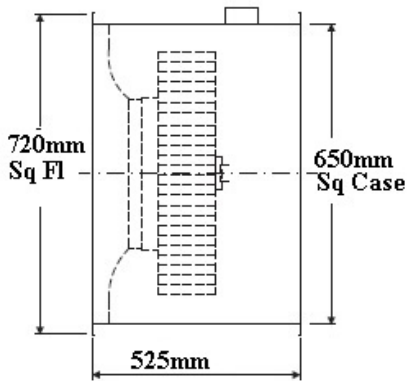

PERFORMANCE



SOUND DATA

Model	Octave Band Frequency Lw db (A)								Lw dB (A)	SPL dB (A) @3m
	63	125	250	500	1K	2K	4K	8K		
IC500-4E	51	68	72	76	71	71	59	68	79	58

TECHNICAL DATA

Fan Model	RPM	1 Phase KW	240V Amps	3 Phase KW	415V Amps	dba @3M
IC500-4E	1386	1.49	6.8			58



**ECO DYNAMIC
FANS PTY LTD**

www.ecodynamicfans.com.au

296 South Gippsland Hwy,
Dandenong South VIC 3175

P: 03 8578 5911

E: sales@ecodynamicfans.com.au

F: 03 8768 8529



IC560-4/6D

INLINE CENTRIFUGAL FAN



FAN FEATURES

- INLINE CENTRIFUGAL FAN. CAPABLE OF HANDLING UP TO 3400 L/s.
- USED FOR COMMERCIAL KITCHEN APPLICATIONS AND GENERAL VENTILATION.
- WEATHER PROOF HOUSING.
- GALVANIZED STEEL CONSTRUCTION.
- SPEED CONTROLLABLE.
- SQUARE FLANGE CONNECTION
- FULL COMPLIANCE WITH AUSTRALIAN STANDARDS AIRFLOW TEST TO BS848 PART 1 & NOISE TEST TO BS848 PART 2

DIMENSIONS

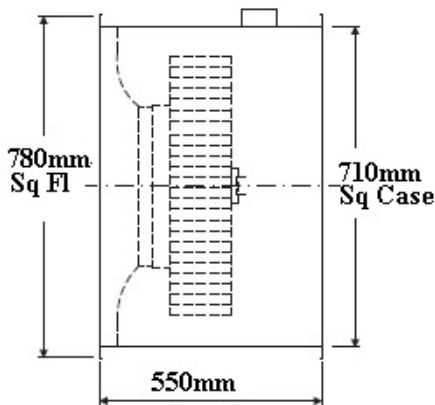

PERFORMANCE

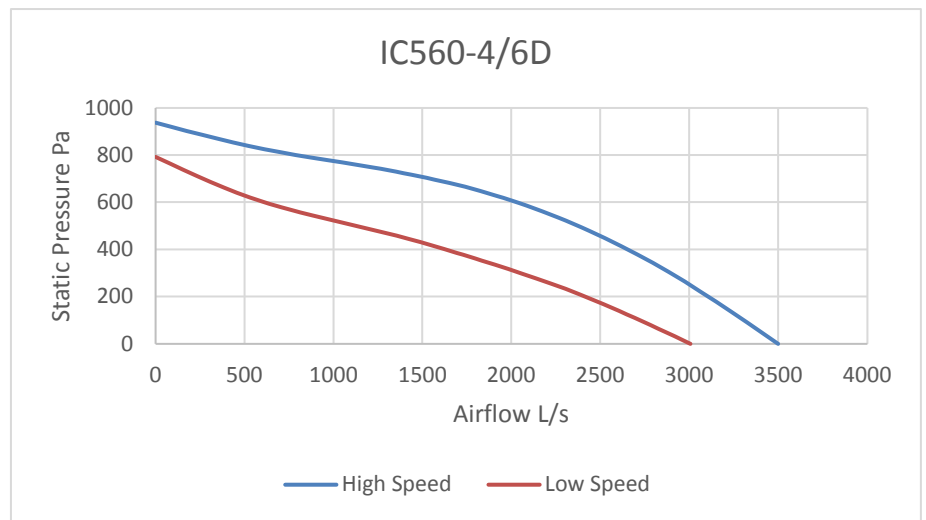

SOUND DATA

Model	Octave Band Frequency Lw db (A)								Lw dB (A)	SPL dB (A) @3m
	63	125	250	500	1K	2K	4K	8K		
IC560-4D	54	75	76	77	74	72	70	68	82	61
IC560-6D	59	61	64	66	64	60	69	62	74	53

TECHNICAL DATA

Fan Model	RPM	1 Phase KW	240V Amps	3 Phase KW	415V Amps	dba @3M
IC560-4D	1330			2.2	4.3	61
IC560-6D	1085			1.51	2.5	53



**ECO DYNAMIC
FANS PTY LTD**

www.ecodynamicfans.com.au

296 South Gippsland Hwy,
Dandenong South VIC 3175

P: 03 8578 5911

E: sales@ecodynamicfans.com.au

F: 03 8768 8529



IC630-4/6D

INLINE CENTRIFUGAL VERTICAL DISCHARGE FAN



FAN FEATURES

- BOX INLINE CENTRIFUGAL FAN CAPABLE OF HANDLING UP TO 4500 L/s.
- USED FOR COMMERCIAL KITCHEN APPLICATIONS AND GENERAL VENTILATION.
- WEATHER PROOF HOUSING.
- GALVANIZED STEEL CONSTRUCTION.
- SPEED CONTROLLABLE, VSD, STAR/DELTA SWITCH OR 5 STEP CONTROLLER
- SQUARE CONNECTION
- 3 PHASE MOTOR 2 SPEED STAR/DELTA
- FULL COMPLIANCE WITH AUSTRALIAN STANDARDS AIRFLOW TEST TO BS848 PART 1 & NOISE TEST TO BS848 PART 2

DIMENSIONS

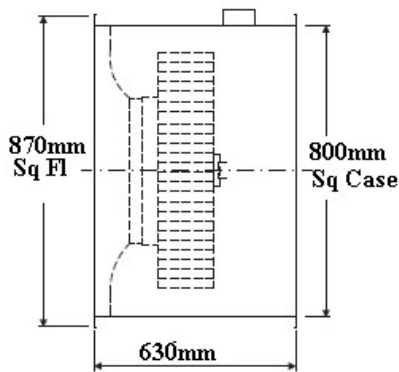

PERFORMANCE

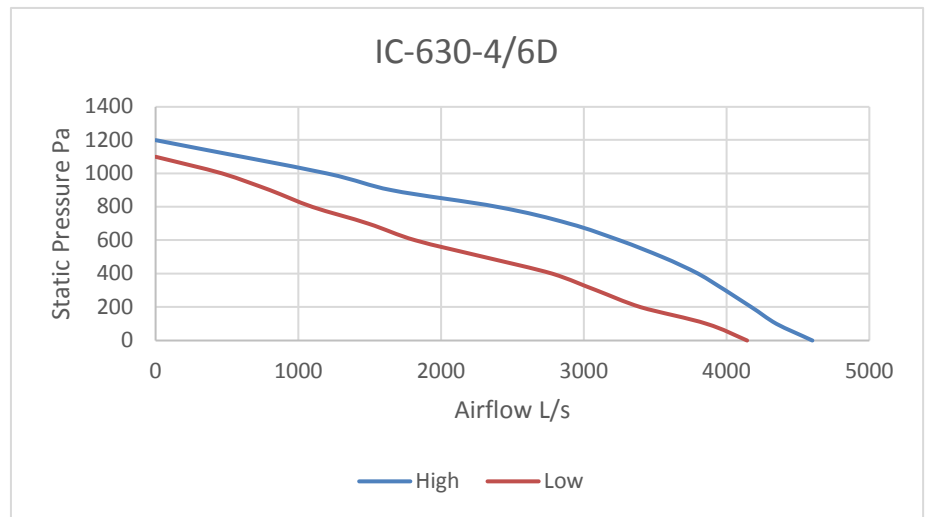

SOUND DATA

Model	Octave Band Frequency Lw db (A)								Lw dB (A)	SPL dB (A) @3m
	63	125	250	500	1K	2K	4K	8K		
IC630-4D	81	86	82	77	78	71	69	64	89	68
IC630-6D	50	60	72	71	63	57	62	77	77	56

TECHNICAL DATA

Fan Model	RPM	1 Phase KW	240V Amps	3 Phase KW	415V Amps	dba @3M
IC630-4D	1380			3.61	6.4	68
IC630-6D	1140			2.66	4.45	56



**ECO DYNAMIC
FANS PTY LTD**

www.ecodynamicfans.com.au

296 South Gippsland Hwy,
Dandenong South VIC 3175

P: 03 8578 5911

E: sales@ecodynamicfans.com.au

F: 03 8768 8529



IC630-6/8D

INLINE CENTRIFUGAL FAN



FAN FEATURES

- INLINE SQUARE BOX FAN CAPABLE OF HANDLING UP TO 2800 L/s.
- USED FOR COMMERCIAL KITCHEN APPLICATIONS AND GENERAL VENTILATION.
- WEATHER PROOF HOUSING.
- GALVANIZED STEEL CONSTRUCTION.
- SPEED CONTROLLABLE , VSD, STAR/DELTA SWITCH OR 5 STEP CONTROLLER
- SQUARE DUCT CONNECTION
- 3 PHASE MOTOR 2 SPEED STAR/DELTA
- FULL COMPLIANCE WITH AUSTRALIAN STANDARDS AIRFLOW TEST TO BS848 PART 1 & NOISE TEST TO BS848 PART 2

DIMENSIONS

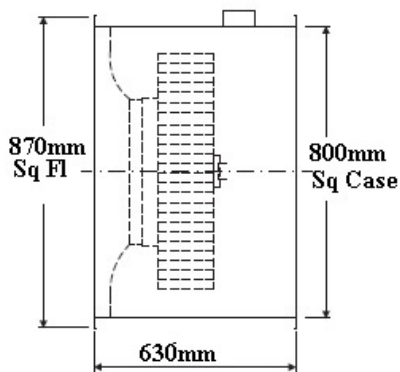

PERFORMANCE

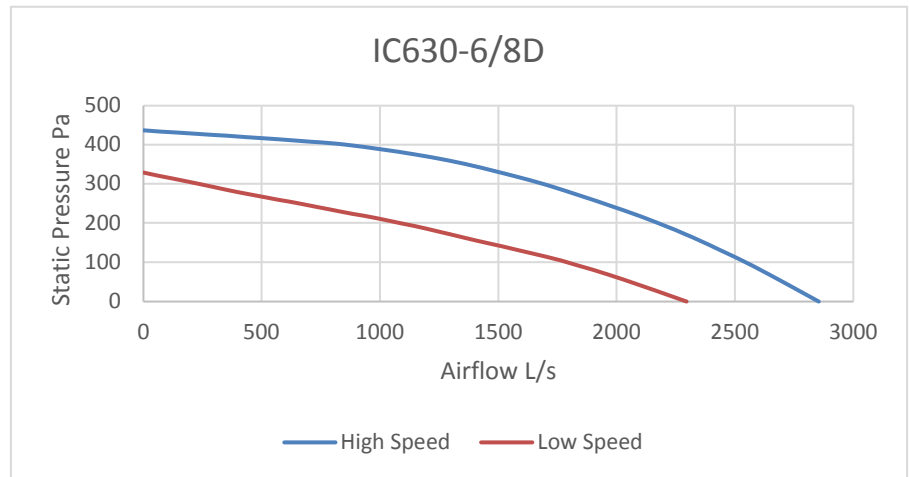

SOUND DATA

Model	Octave Band Frequency Lw db (A)								Lw dB (A)	SPL dB (A) @3m
	63	125	250	500	1K	2K	4K	8K		
IC630-6D	52	60	68	68	66	68	73	74	78	57
IC630-8D	44	52	60	60	58	60	65	66	70	49

TECHNICAL DATA

Fan Model	RPM	1 Phase KW	240V Amps	3 Phase KW	415V Amps	dba @3M
IC630-6D	860			1.1	2.1	57
IC630-8D	670			0.66	1.15	49



**ECO DYNAMIC
FANS PTY LTD**

296 South Gippsland Hwy,
Dandenong South VIC 3175

P: 03 8578 5911

E: sales@ecodynamicfans.com.au

F: 03 8768 8529

www.ecodynamicfans.com.au



IC710-6/8D

INLINE CENTRIFUGAL FAN



FAN FEATURES

- INLINE SQUARE BOX FAN CAPABLE OF HANDLING UP TO 3800 L/s.
- USED FOR COMMERCIAL KITCHEN APPLICATIONS AND GENERAL VENTILATION.
- WEATHER PROOF HOUSING.
- GALVANIZED STEEL CONSTRUCTION.
- SPEED CONTROLLABLE , VSD, STAR/DELTA SWITCH OR 5 STEP CONTROLLER
- SQUARE DUCT CONNECTION
- 3 PHASE MOTOR 2 SPEED STAR/DELTA
- FULL COMPLIANCE WITH AUSTRALIAN STANDARDS AIRFLOW TEST TO BS848 PART 1 & NOISE TEST TO BS848 PART 2

DIMENSIONS

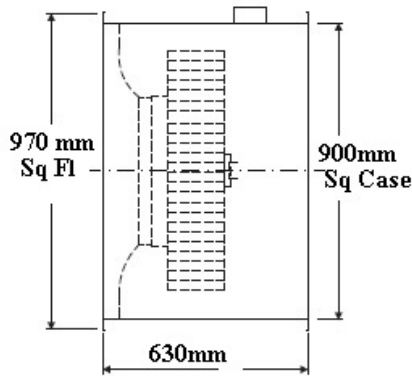

PERFORMANCE

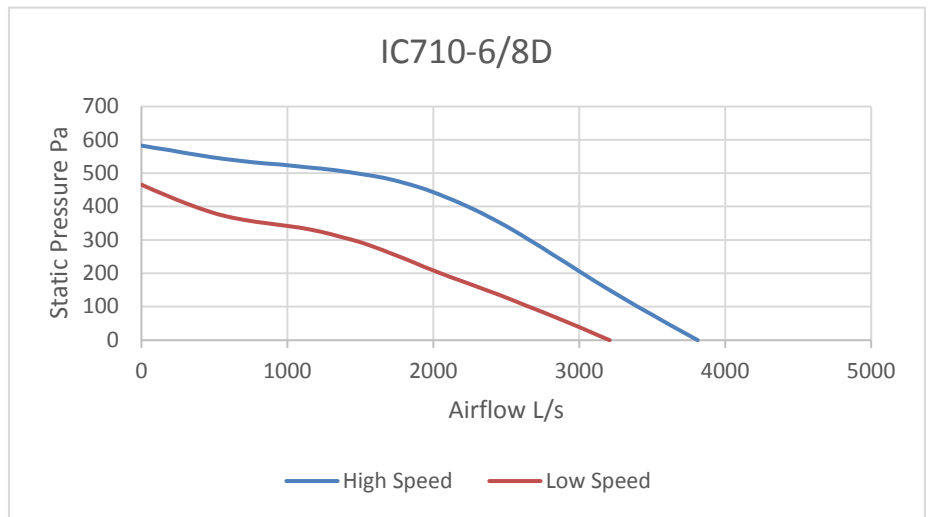

SOUND DATA

Model	Octave Band Frequency Lw db (A)								Lw dB (A)	SPL dB (A) @3m
	63	125	250	500	1K	2K	4K	8K		
IC710-6D	59	71	79	72	73	71	62	81	84	63
IC710-8D	61	63	66	68	66	62	71	64	76	55

TECHNICAL DATA

Fan Model	RPM	1 Phase KW	240V Amps	3 Phase KW	415V Amps	dba @3M
IC710-6D	910			2.1	4.1	63
IC710-8D	715			1.4	2.6	55



**ECO DYNAMIC
FANS PTY LTD**

296 South Gippsland Hwy,
Dandenong South VIC 3175

P: 03 8578 5911

E: sales@ecodynamicfans.com.au

F: 03 8768 8529

w w w . e c o d y n a m i c f a n s . c o m . a u