

Catalog

SPA-200-2E.pdf	1
SPA-200-4E.pdf	2
SPA-250-2E.pdf	3
SPA-250-4E.pdf	4
SPA-300-2E.pdf	5
SPA-300-4E.pdf	6
SPA-350-4E.pdf	7



SPA200-2E

SQUARE PLATE AXIAL FANS



FAN FEATURES

- SQUARE PLATE AXIAL FAN. CAPABLE OF HANDLING UP TO 220 L/s.
- USED FOR TOILET EXHAUST AND GENERAL VENTILATION.
- SPEED CONTROLLABLE.
- CIRCULAR CONNECTION
- FULL COMPLIANCE WITH AUSTRALIAN STANDARDS AIRFLOW TEST TO BS848 PART 1 & NOISE TEST TO BS848 PART 2

DIMENSIONS

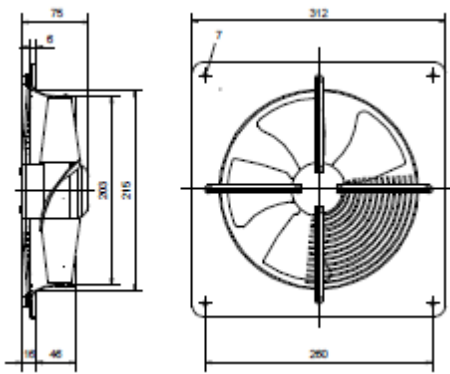

PERFORMANCE

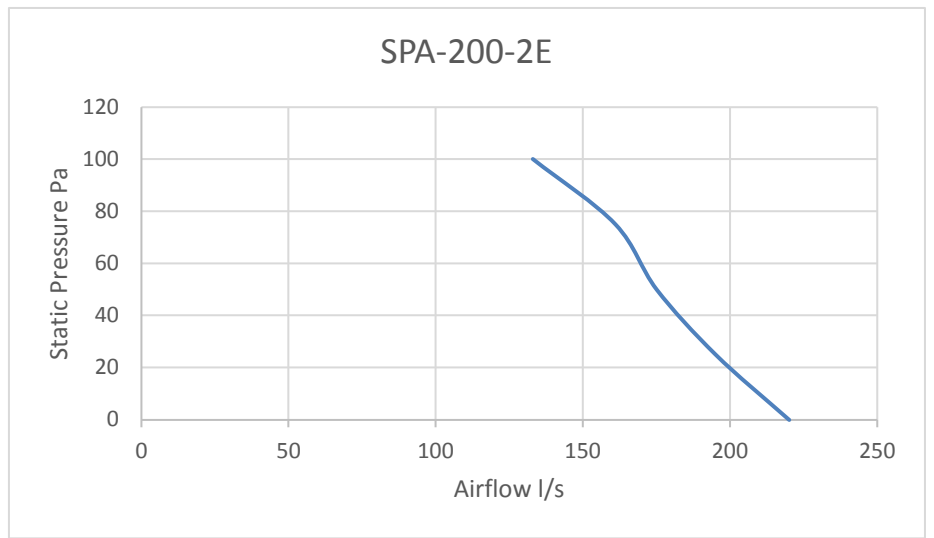

SOUND DATA

Model	Octave Band Frequency Lw db (A)								Lw dB (A)	SPL dB (A) @3m
	63	125	250	500	1K	2K	4K	8K		
SPA200-2E		42	55	58	60	61	58	51	66	44

TECHNICAL DATA

Fan Model	RPM	1 Phase KW	240V Amps	3 Phase KW	415V Amps	dba @3M
SPA-200-2E	2550	0.07	0.30			44



ECO DYNAMIC FANS PTY LTD

296 South Gippsland Hwy,
Dandenong South VIC 3175

P: 03 8578 5911

E: sales@ecodynamicfans.com.au

F: 03 8768 8529

www.ecodynamicfans.com.au



SPA200-4E

SQUARE PLATE AXIAL FANS

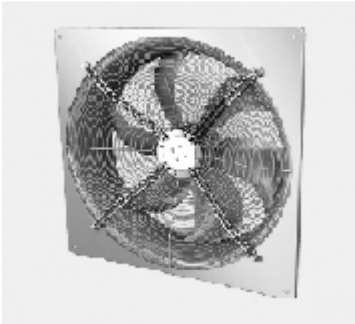

FAN FEATURES

- SQUARE PLATE AXIAL FAN. CAPABLE OF HANDLING UP TO 132 L/s.
- USED FOR TOILET EXHAUST AND GENERAL VENTILATION.
- SPEED CONTROLLABLE.
- CIRCULAR CONNECTION
- FULL COMPLIANCE WITH AUSTRALIAN STANDARDS AIRFLOW TEST TO BS848 PART 1 & NOISE TEST TO BS848 PART 2

DIMENSIONS

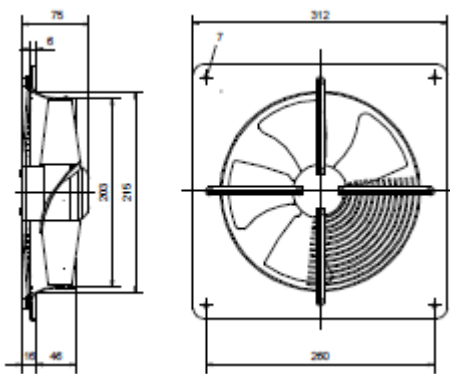

PERFORMANCE

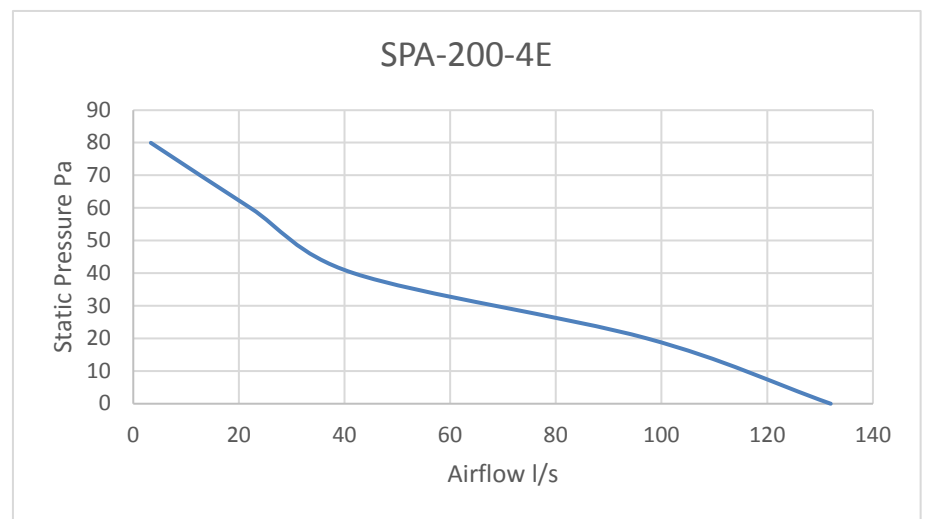

SOUND DATA

Model	Octave Band Frequency Lw db (A)								Lw dB (A)	SPL dB (A) @3m
	63	125	250	500	1K	2K	4K	8K		
SPA200-4E		35	38	44	45	44	39	27	49	28

TECHNICAL DATA

Fan Model	RPM	1 Phase KW	240V Amps	3 Phase KW	415V Amps	dba @3M
SPA-200-4E	1390	0.032	0.15			28



ECO DYNAMIC FANS PTY LTD

www.ecodynamicfans.com.au

296 South Gippsland Hwy,
Dandenong South VIC 3175
P: 03 8578 5911
E: sales@ecodynamicfans.com.au
F: 03 8768 8529



SPA250-2E

SQUARE PLATE AXIAL FANS

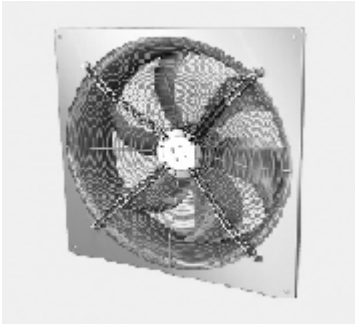

FAN FEATURES

- SQUARE PLATE AXIAL FAN. CAPABLE OF HANDLING UP TO 445 L/s.
- USED FOR TOILET EXHAUST AND GENERAL VENTILATION.
- SPEED CONTROLLABLE.
- CIRCULAR CONNECTION
- FULL COMPLIANCE WITH AUSTRALIAN STANDARDS AIRFLOW TEST TO BS848 PART 1 & NOISE TEST TO BS848 PART 2

DIMENSIONS

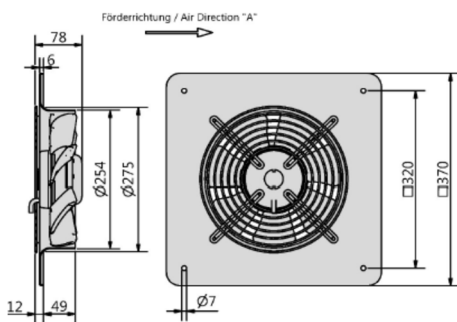

PERFORMANCE



SOUND DATA

Model	Octave Band Frequency Lw db (A)								Lw dB (A)	SPL dB (A) @3m
	63	125	250	500	1K	2K	4K	8K		
SPA250-2E		46	62	68	67	66	64	57	73	51

TECHNICAL DATA

Fan Model	RPM	1 Phase KW	240V Amps	3 Phase KW	415V Amps	dba @3M
SPA250-2E	2650	0.123	0.54			51



**ECO DYNAMIC
FANS PTY LTD**

www.ecodynamicfans.com.au

296 South Gippsland Hwy,
Dandenong South VIC 3175
P: 03 8578 5911
E: sales@ecodynamicfans.com.au
F: 03 8768 8529



SPA250-4E

SQUARE PLATE AXIAL FANS

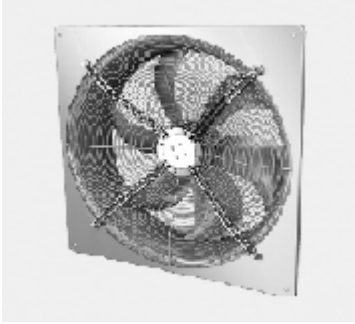

FAN FEATURES

- SQUARE PLATE AXIAL FAN. CAPABLE OF HANDLING UP TO 290 L/s.
- USED FOR TOILET EXHAUST AND GENERAL VENTILATION.
- SPEED CONTROLLABLE.
- CIRCULAR CONNECTION
- FULL COMPLIANCE WITH AUSTRALIAN STANDARDS AIRFLOW TEST TO BS848 PART 1 & NOISE TEST TO BS848 PART 2

DIMENSIONS

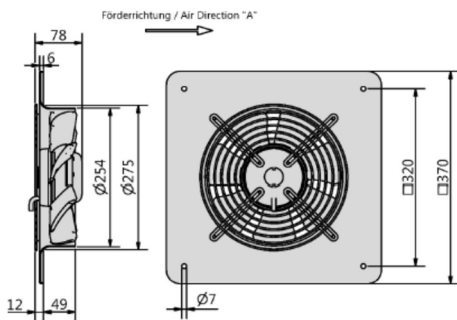

PERFORMANCE

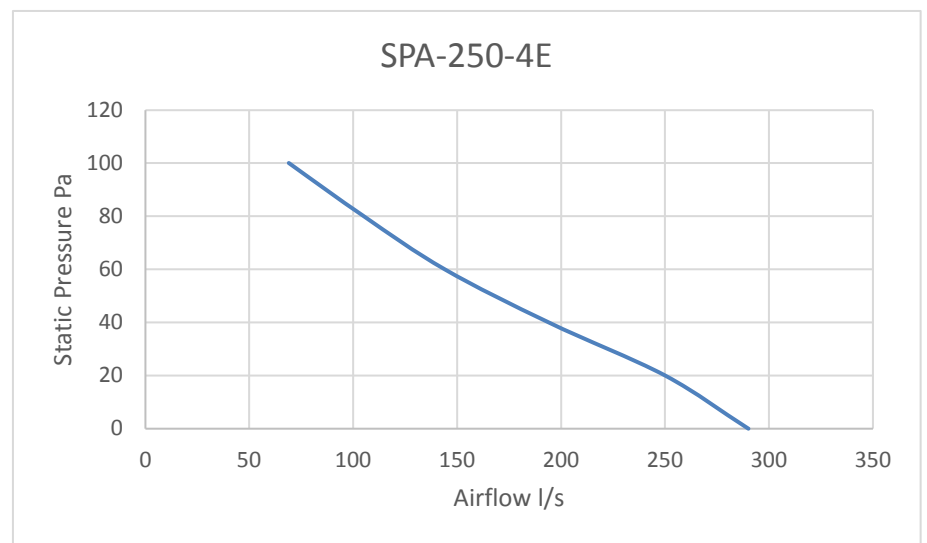

SOUND DATA

Model	Octave Band Frequency Lw db (A)								Lw dB (A)	SPL dB (A) @3m
	63	125	250	500	1K	2K	4K	8K		
SPA250-4E		41	47	50	51	52	47	36	57	36

TECHNICAL DATA

Fan Model	RPM	1 Phase KW	240V Amps	3 Phase KW	415V Amps	dba @3M
SPA250-4E	1315	0.054	0.25			36



**ECO DYNAMIC
FANS PTY LTD**

www.ecodynamicfans.com.au

296 South Gippsland Hwy,
Dandenong South VIC 3175
P: 03 8578 5911
E: sales@ecodynamicfans.com.au
F: 03 8768 8529



SPA300-2E

SQUARE PLATE AXIAL FANS

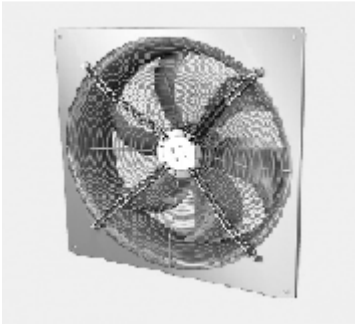

FAN FEATURES

- SQUARE PLATE AXIAL FAN. CAPABLE OF HANDLING UP TO 780 L/s.
- USED FOR TOILET EXHAUST AND GENERAL VENTILATION.
- SPEED CONTROLLABLE.
- CIRCULAR CONNECTION
- FULL COMPLIANCE WITH AUSTRALIAN STANDARDS AIRFLOW TEST TO BS848 PART 1 & NOISE TEST TO BS848 PART 2

DIMENSIONS

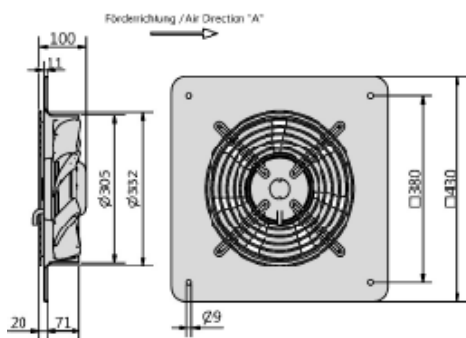

PERFORMANCE

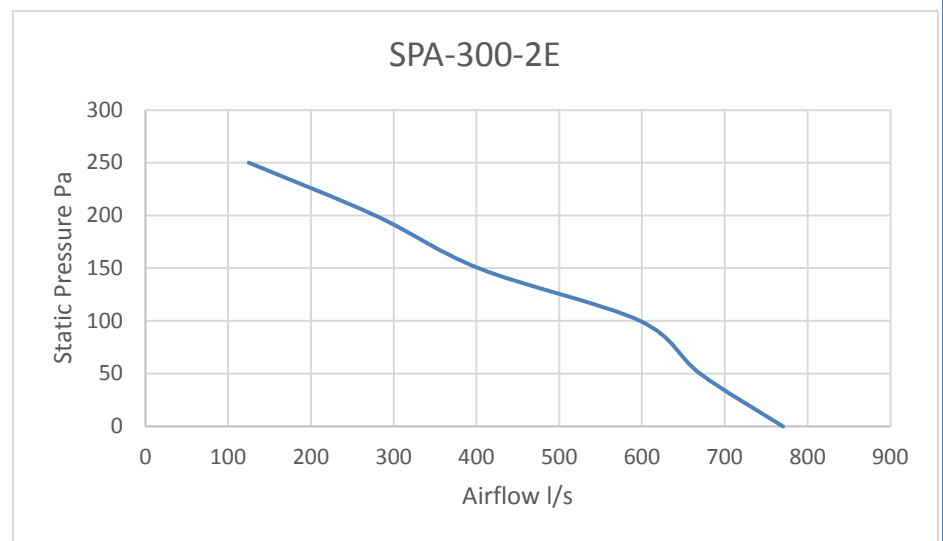

SOUND DATA

Model	Octave Band Frequency Lw db (A)								Lw dB (A)	SPL dB (A) @3m
	63	125	250	500	1K	2K	4K	8K		
SPA300-2E		55	64	74	73	73	70	62	79	58

TECHNICAL DATA

Fan Model	RPM	1 Phase KW	240V Amps	3 Phase KW	415V Amps	dba @3M
SPA300-2E	2505	0.21	0.9			58



ECO DYNAMIC FANS PTY LTD

www.ecodynamicfans.com.au

296 South Gippsland Hwy,
Dandenong South VIC 3175
P: 03 8578 5911
E: sales@ecodynamicfans.com.au
F: 03 8768 8529



SPA300-4E

SQUARE PLATE AXIAL FANS



FAN FEATURES

- SQUARE PLATE AXIAL FAN. CAPABLE OF HANDLING UP TO 500 L/s.
- USED FOR TOILET EXHAUST AND GENERAL VENTILATION.
- SPEED CONTROLLABLE.
- CIRCULAR CONNECTION
- FULL COMPLIANCE WITH AUSTRALIAN STANDARDS AIRFLOW TEST TO BS848 PART 1 & NOISE TEST TO BS848 PART 2

DIMENSIONS

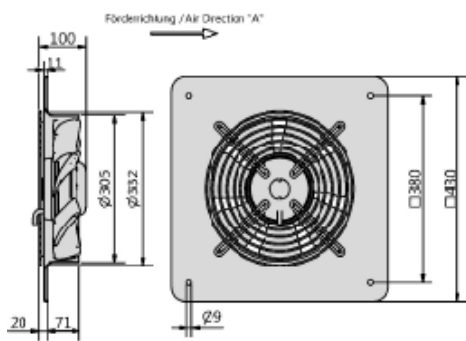

PERFORMANCE

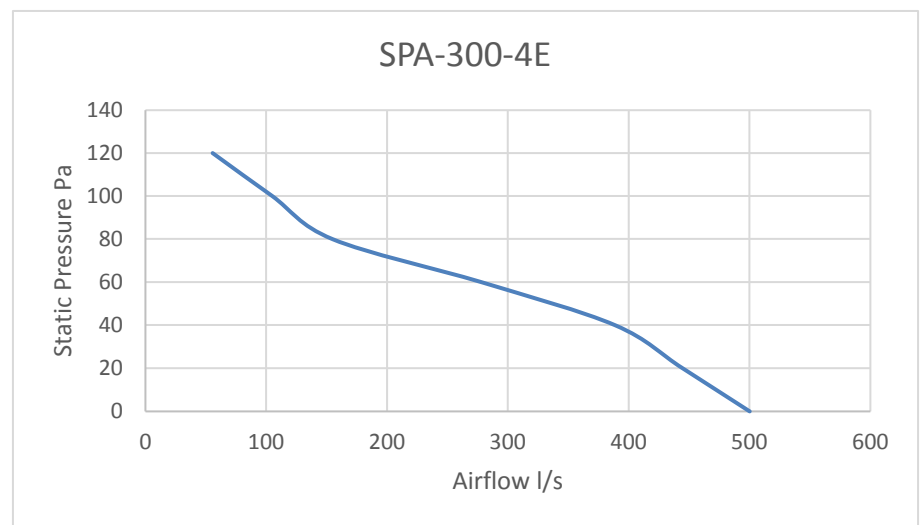

SOUND DATA

Model	Octave Band Frequency Lw db (A)								Lw dB (A)	SPL dB (A) @3m
	63	125	250	500	1K	2K	4K	8K		
SPA300-4E		46	53	54	55	55	51	39	60	39

TECHNICAL DATA

Fan Model	RPM	1 Phase KW	240V Amps	3 Phase KW	415V Amps	dba @3M
SPA300-4E	1280	0.096	0.43			39



**ECO DYNAMIC
FANS PTY LTD**

296 South Gippsland Hwy,
Dandenong South VIC 3175
P: 03 8578 5911
E: sales@ecodynamicfans.com.au
F: 03 8768 8529

www.ecodynamicfans.com.au



SPA350-4E

SQUARE PLATE AXIAL FANS

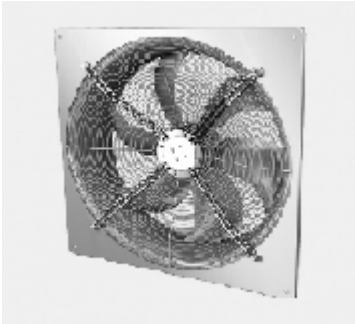

FAN FEATURES

- SQUARE PLATE AXIAL FAN. CAPABLE OF HANDLING UP TO 925 L/s.
- USED FOR TOILET EXHAUST AND GENERAL VENTILATION.
- SPEED CONTROLLABLE.
- CIRCULAR CONNECTION
- FULL COMPLIANCE WITH AUSTRALIAN STANDARDS AIRFLOW TEST TO BS848 PART 1 & NOISE TEST TO BS848 PART 2

DIMENSIONS

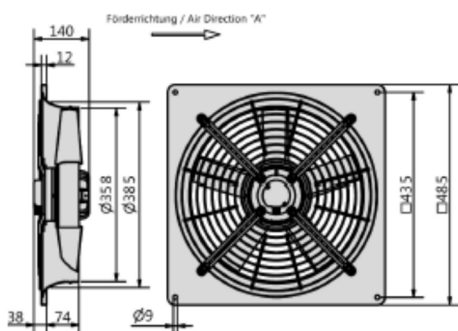

PERFORMANCE

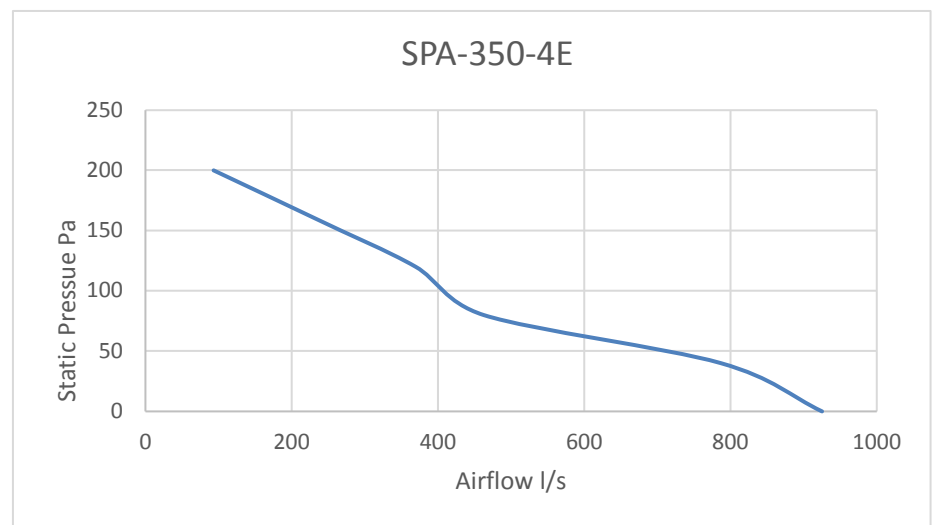

SOUND DATA

Model	Octave Band Frequency Lw db (A)								Lw dB (A)	SPL dB (A) @3m
	63	125	250	500	1K	2K	4K	8K		
SPA350-4E		48	56	62	64	65	63	54	69	48

TECHNICAL DATA

Fan Model	RPM	1 Phase KW	240V Amps	3 Phase KW	415V Amps	dba @3M
SPA350-4E	1385	0.16	0.76			48



**ECO DYNAMIC
FANS PTY LTD**

296 South Gippsland Hwy,
Dandenong South VIC 3175
P: 03 8578 5911
E: sales@ecodynamicfans.com.au
F: 03 8768 8529

www.ecodynamicfans.com.au